

REACH Wireless®

Heat Detector



Product overview

Product	REACH Wireless Heat Detector
Part No.	RW1000-400APO
Product	REACH Wireless Heat Detector - Black Body
Part No.	RW1000-460APO
Digital Communication	Apollo protocol compatibility is handled via the Loop-Interface device, RW1700-030APO. See product for more detail.

Product information

The RW1000-400APO and RW1000-460APO are wireless analogue addressable heat detectors that can be configured as either rate-of-rise (A1R) or high temperature (BS) classification as specified in the EN 54-5. Multiple EN 54-5 classes (either A1R and BS) can be configured via the Loop-Interface during setup.

- Twin alarm, bi-colour LEDs for 360° visibility
- Programmable for rate-of-rise (A1R) or static temperature (BS)
- Bi-directional wireless communication
- Dual channel redundancy
- Ten year battery life
- Five year product warranty

Manufacturer's Specification

All data is supplied subject to change without notice. Specifications are typical at 24 V, 25°C and 50% RH unless otherwise stated.

Detection principle	Single NTC thermistor
Communication Range between Loop-Interface and Devices	100 m (in open space)
Field Device Radio Frequency Channel Pairs	22 pairs
Status LED	Green and Red
Radiated Power	14 dBm (25 mW)
Battery Type	2x VARTA CR123A Lithium 3 V, 1250mAh typical
Battery Lifespan	10 years in normal operation with good signal strength (no dropped messages)
Operating Temperature	-10°C to +55°C
Maximum Relative Humidity (non-condensing)	95%
IP Rating	40
Dimensions	110 mm diameter x 70 mm height
Weight (including base and batteries)	190 g

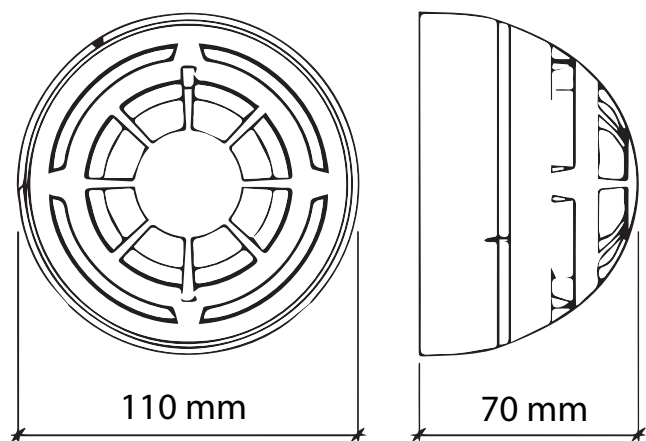

Operating Principles

The REACH Wireless Heat Detectors are flexible – offering either static (BS) or rate-of-rise (A1R) functionality.

Status LED

It also includes a 360° LED indicator which illuminates red or green to indicate status conditions.

Device Addressing

Device addressing is handled by the REACH Wireless Loop-Interface device (RW1700-030APO).

Devices are soft-addressed automatically when pairing with the Loop Interface and can be changed manually. Hard-addressing using Apollo XPERT cards are not supported.

Table 1: REACH Wireless Device Indication

Device Status	LED Indication
Power Up	Blinks green four times
Power Up (dip-switch ON)	Blinks red four times
Entering Wake-Up	Blinks alternatively green/red four times
Link Success	Blinks green four times, then repeats
Link Failure	Enters wake-up mode and signals 'Entering wake-up mode' following this failure
Normal Condition	LED off
Alarm	Red 1s, period 2s
Battery Faults	LED off
Tamper Fault	LED off
Replaced	Blinks amber two times

Communication

REACH Wireless Devices use 'radio-frequency' wireless communication to connect to the Loop-Interface.

The Loop-Interface (RW1700-030APO / RW1700-031APO) translates the wireless communication into wired Apollo protocol communication, with each device addressable individually by the fire panel. See datasheets for the Loop-Interface for more information.

Maintenance and Service

Maintenance must be performed in accordance with all applicable standards. Clean the detector externally using a soft damp cloth. For full cleaning and recalibration detectors should be returned to Apollo Fire Detectors.

Tamper detection

REACH Wireless devices contain an anti-tamper mechanism. In the event of removal from its base, it sends a tamper detection message to the Loop-Interface. Tampering detection is not signalled visually by the device

Base Compatibility

The device is supplied with a standard wireless base and is compatible with the following sounder bases:

Table 2: REACH Wireless Base Compatibility

Part Number	Product Name
RW1300-110APO	REACH Wireless Sounder Base
RW1300-210APO	REACH Wireless Sounder VAD Base (White Flash) (C-3-15)
RW1300-211APO	REACH Wireless Sounder VAD Base (Red Flash) (C-3-10)
RW1300-160APO	REACH Wireless Sounder Base - Black Body
RW1300-260APO	REACH Wireless Sounder VAD Base - Black Body (White-Flash) (C-3-15)

Batteries

REACH Wireless devices are supplied with two CR123 batteries, battery A and B. The device switches periodically between the two batteries on a controlled sequence. For correct operation of the device, both batteries are required with adequate capacity reserves.

When battery A reaches a low power threshold, it will trigger a fault. This fault requires both batteries to be replaced in every instance as both batteries should be discharging equally.

When one (or both) batteries lack power, the Loop-Interface receives a low battery message and will signal this event on its in-built display, as well as relay the low battery message to the fire control panel. The battery fault will also be signalled by the device itself through its LED indicators if programmed (see table 1).

EMC Directive 2014/30/EU

REACH Wireless Heat Detector complies with the essential requirements of the EMC Directive 2014/30/EU, provided that it is used as described in this datasheet.

A copy of the Declaration of Conformity is available from Apollo on request.

Conformity of the REACH Wireless Heat Detector with the EMC Directive does not confer compliance with the directive on any apparatus or systems connected to it.

Construction Products Regulation (EU) 305/2011

The REACH Wireless Heat Detector complies with the essential requirements of the Construction Products Regulation (EU) 305/2011

A copy of the Declaration of Performance is available from Apollo on request.